

## 3-PC BALL VALVE THREAD/SOCKET WELD END

三片式内螺纹承插焊球阀

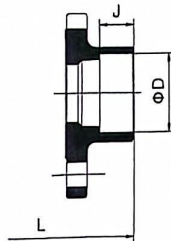
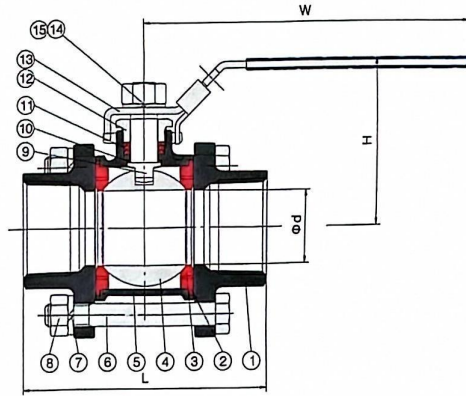

Socket weld end

### 特点 Features

- 全通径 Full port, 1/4"~4" (DN6-DN100)
- 工作压力 W.P.: 1000WOG (PN63)
- 工作温度 W.T.: -20°C~180°C
- 精密铸造 Investment casting
- 阀杆防爆出装置设计 Blow-out proof stem
- 手柄带锁装置 (可选) Locking device handle (option)
- 螺纹连接标准 Thread type: ASME B1.20.1 (NPT),  
DIN 259 / DIN 2999, BS 21,  
ISO 288-1, ISO 7-1
- 承插焊连接标准 Socket weld type: ASME B16.11 & DIN3239 part2

### 材料表 Material List

序号No.	零件 PARTS	材料 MATERIAL		
		WCB	CF8	CF8M
1	阀盖 BONNET	WCB	CF8	CF8M
2	垫片 GASKET	PTFE		
3	阀座 SEAT	PTFE		
4	球体 BALL	CF8	CF8	CF8M
5	阀体 BODY	WCB	CF8	CF8M
6	螺栓 BOLT	304		
7	弹簧垫圈 SPRING WASHER	304		
8	螺母 NUT	304		
9	阀杆 STEM	304	304	316
10	阀杆垫圈 STEM WASHER	PTFE		
11	填料 PACKING	PTFE		
12	填料盖 GLAND	304		
13	手柄 HANDLE	304+PVC		
14	弹簧垫圈 SPRING WASHER	304		
15	螺母 NUT	304		

### 尺寸 Dimensions

Unit: mm

尺寸 SIZE	d	L	H	W	D	J
1/4"	DN6	10	67	52	95	14.2
3/8"	DN10	12	67	52	95	17.6
1/2"	DN15	15	72	55	105	21.8
3/4"	DN20	20	80.5	59	128	27.2
1"	DN25	25	92	66	145	33.9
1-1/4"	DN32	32	110	71	145	42.7
1-1/2"	DN40	38	118	82	160	48.8
2"	DN50	50	141	90	190	61.2
2-1/2"	DN65	65	169	122	220	73.9
3"	DN80	80	198	135	250	89.8
4"	DN100	100	245	156	300	115.2

## 3-PC BALL VALVE BUTT WELD END

三片式对焊球阀

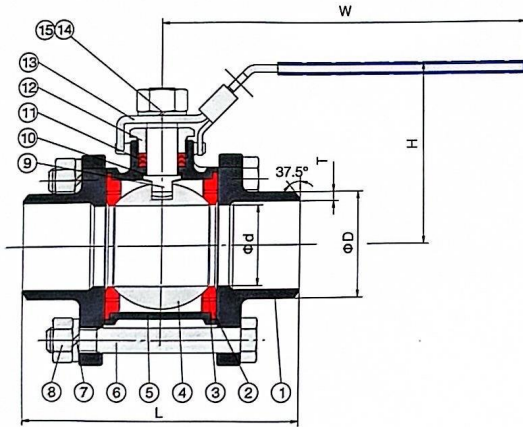
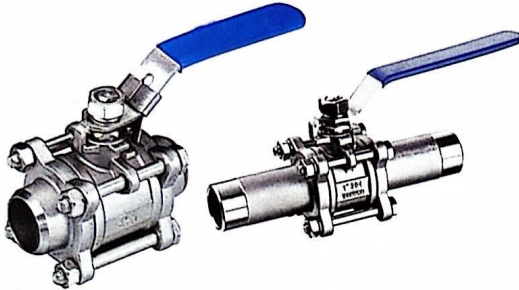

### 特点 Features

- 全通径 Full port, 1/4"~6" (DN6~DN150)
- 工作压力 W.P.: 1000WOG (PN63)
- 工作温度 W.T.: -20°C~180°C
- 精密铸造 Investment casting
- 阀杆防爆出装置设计 Blow-out proof stem
- 手柄带锁装置(可选) Locking device handle (option)
- ISO5211直装高平台设计(可选) ISO5211 Direct mounting pad (option)
- 对焊连接标准 Butt weld type: ASME B16.25 & DIN3239 part1

### 材料表 Material List

序号No.	零件 PARTS	材料 MATERIAL		
		WCB	CF8	CF8M
1	阀盖 BONNET	WCB	CF8	CF8M
2	垫片 GASKET	PTFE		
3	阀座 SEAT	PTFE		
4	球体 BALL	CF8	CF8	CF8M
5	阀体 BODY	WCB	CF8	CF8M
6	螺栓 BOLT	304		
7	弹簧垫圈 SPRING WASHER	304		
8	螺母 NUT	304		
9	阀杆 STEM	304	304	316
10	阀杆垫圈 STEM WASHER	PTFE		
11	填料 PACKING	PTFE		
12	填料盖 GLAND	304		
13	手柄 HANDLE	304+PVC		
14	弹簧垫圈 SPRING WASHER	304		
15	螺母 NUT	304		

### 尺寸 Dimensions

Unit: mm

尺寸 SIZE		d	L	D	T	H	W
1/4"	DN6	10	64	14.5	2.25	52	95
3/8"	DN10	12	64	17.5	2.75	52	95
1/2"	DN15	15	71.5	21.5	3.0	55	105
3/4"	DN20	20	81.5	27	3.0	59	128
1"	DN25	25	92	34	3.5	66	145
1-1/4"	DN32	32	107	42.5	3.7	71	145
1-1/2"	DN40	38	118	48.5	4.0	82	160
2"	DN50	50	142.5	60.5	4.0	90	190
2-1/2"	DN65	65	176	74	4.5	122	220
3"	DN80	80	198	90	5.0	135	250
4"	DN100	100	242	114.5	6.0	156	300

## 3-PC BALL VALVE THREAD END DIRECT MOUNTING PAD

三片式高平台球阀 ( 螺纹/对焊/承插焊 )

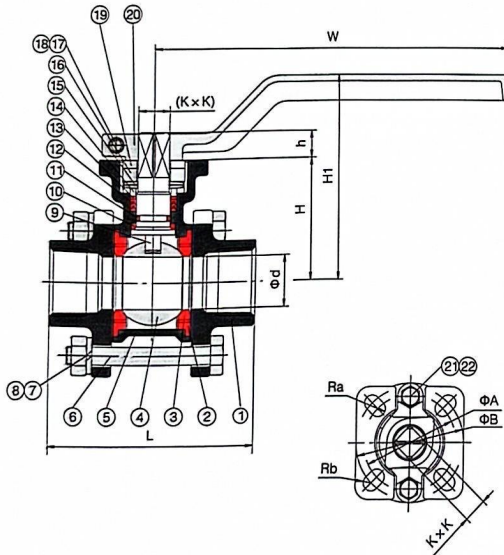
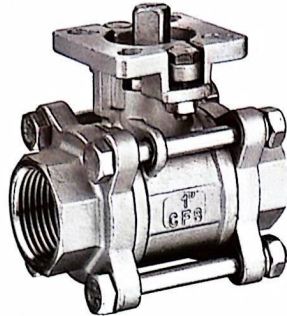

### 特点 Features

- 全通径 Full port, 1/4"~4" (DN6~DN100)
- 工作压力 W.P.: 1000WOG (PN63)
- 工作温度 W.T.: -20°C~180°C
- 精密铸造 Investment casting
- 阀杆防爆出装置设计 Blow-out proof stem
- 双螺旋弹簧动负载设计 Live-loading design
- 防静电装置 ( 可选 ) Anti-static device (option)
- 带锁手柄 Locking device handle
- ISO5211直装高平台设计 ISO 5211 Direct mounting pad
- 自动化装置 ( 可选 ) Automation accessories (option)
- 螺纹连接标准 Thread type: ASME B1.20.1 (NPT), DIN 259 / DIN 2999, BS 21, ISO 288-1, ISO 7-1
- 承插焊连接标准 Socket weld type: ASME B16.11 & DIN3239 part2
- 对焊连接标准 Butt weld type: ASME B16.25 & DIN3239 part1

### 材料表 Material List

序号No.	零件 PARTS	材料 MATERIAL		
		WCB	CF8	CF8M
1	阀盖 BONNET	WCB	CF8	CF8M
2	垫片 GASKET	PTFE		
3	阀座 SEAT	PTFE		
4	球体 BALL	CF8	CF8	CF8M
5	阀体 BODY	WCB	CF8	CF8M
6	螺栓 BOLT	304		
7	弹簧垫圈 SPRING WASHER	304		
8	螺母 NUT	304		
9	阀杆 STEM	304	304	316
10	阀杆垫圈 STEM WASHER	PTFE+25% GF		
11	O 形圈 O-RING	FPM		
12	填料 PACKING	PTFE		
13	耐磨垫圈 WEAR WASHER	PTFE+25% GF		
14	填料盖 GLAND	304		
15	碟形弹簧 DISC SPRING	304		
16	压盖法兰 GLAND FLANGE	CF8		
17	六角螺栓 HEX SOCKET BOLT	304		
18	螺母 NUT	304		
19	STOPPER	304		
20	手柄 HANDLE	WCB/CF8		
21	螺栓 BOLT	304		
22	螺母 NUT	304		

### 尺寸 Dimensions

Unit: mm

尺寸 SIZE	d	L	H	h	KxK	A	B	Ra	Rb	W	H1	D	J	L1	D1	T	
1/4"	DN6	10	68	43	9	9×9	36	42	3.0	3.0	140	75	14.2	9.5	63	14.5	2.25
3/8"	DN10	12	68	43	9	9×9	36	42	3.0	3.0	140	75	17.6	9.5	63	17.5	2.75
1/2"	DN15	15	68.5	43	9	9×9	36	42	3.0	3.0	140	75	21.8	9.5	70	21.5	3.0
3/4"	DN20	20	79	47	9	9×9	36	42	3.0	3.0	140	79	27.2	12.5	80	27	3.0
1"	DN25	25	89	57	11	11×11	42	50	3.0	3.5	170	92	33.9	12.5	90	34	3.5
1-1/4"	DN32	32	100.5	63	11	11×11	42	50	3.0	3.5	170	98	42.7	12.5	104	42.5	3.7
1-1/2"	DN40	38	111	72	14	14×14	50	70	3.5	4.5	200	110	48.8	12.5	116	48.5	4
2"	DN50	50	129	80	14	14×14	50	70	3.5	4.5	200	118	61.2	16	138	60.5	4
2-1/2"	DN65	65	169.5	98	17	17×17	70	102	4.5	5.5	300	142	73.9	16	182	74	4.5
3"	DN80	80	191	110	17	17×17	70	102	4.5	5.5	300	154	89.8	16	203	90	5
4"	DN100	100	242	132	17	17×17	70	102	4.5	5.5	300	176	115.2	19	252	114.5	6

## 3-PC BALL VALVE CLAMP END DIRECT MOUNTING PAD

三片式快装高平台球阀

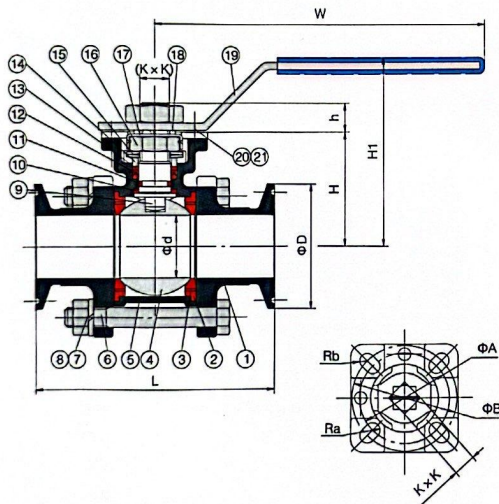

### 特点 Features

- 全口径 Full port, 1/2"~4" (DN15~DN100)
- 工作压力 W.P.: 1000WOG (PN63)
- 工作温度 W.T.: -20°C~180°C
- 精密铸造 Investment casting
- 阀杆防爆出装置设计 Blow-out proof stem
- 双螺旋弹簧动负载设计 Live-loading design
- 防静电装置 (可选) Anti-static device (option)
- 全包式阀座 (可选) Cavity filled seats (option)
- 手柄带锁装置 (可选) Locking device handle (option)
- ISO5211直装高平台设计 ISO 5211 Direct mounting pad
- 自动化装置 (可选) Automation accessories (option)
- 快装连接标准 Clamp end type: ASME BPE

### 材料表 Material List

序号No.	零件 PARTS	材料 MATERIAL		
		CF8	CF8M	CF3M
1	阀盖 BONNET	CF8	CF8M	CF3M
2	垫片 GASKET	PTFE/TFM1600		
3	阀座 SEAT	PTFE/TFM1600		
4	球体 BALL	CF8	CF8M	CF3M
5	阀体 BODY	CF8	CF8M	CF3M
6	螺栓 BOLT	304		
7	弹簧垫圈 SPRING WASHER	304		
8	螺母 NUT	304		
9	阀杆 STEM	304	316	316L
10	阀杆垫圈 STEM WASHER	PTFE+25% GF		
11	O 形圈 O-RING	FPM		
12	填料 PACKING	PTFE		
13	耐磨垫圈 WEAR WASHER	PTFE+25% GF		
14	填料盖 GLAND	304		
15	碟形弹簧 DISC SPRING	304		
16	螺母 NUT	304		
17	CROWN WASHER	304		
18	垫圈 WASHER	304		
19	手柄 HANDLE	304+PVC		
20	六角螺栓 HEX SOCKET BOLT	304		
21	螺母 NUT	304		

### 尺寸 Dimensions

Unit: mm

尺寸 SIZE		d	D	L	H	h	KxK	A	B	Ra	Rb	W	H1
1/2'	DN15	10	25	98	38	9	9 × 9	36	42	3.0	3.0	125	72
3/4'	DN20	15	25	107	42	9	9 × 9	36	42	3.0	3.0	125	76
1'	DN25	22	50.4	112.5	48	9	9 × 9	36	42	3.0	3.0	125	82
1-1/2'	DN40	35	50.4	125	61	9	9 × 9	42	50	3.0	3.5	140	95
2'	DN50	47.5	63.9	140	79	14	14 × 14	50	70	3.5	4.5	180	115
2-1/2'	DN65	59	77.4	157	88	14	14 × 14	70	102	4.5	5.5	180	124
3'	DN80	73	90.9	178	108	17	17 × 17	70	102	4.5	5.5	260	148
4'	DN100	97.5	118.9	202	130	17	17 × 17	70	102	4.5	5.5	260	170

## 3-PC BALL VALVE BALL WELD END DIRECT MOUNTING PAD

三片式焊接高平台球阀

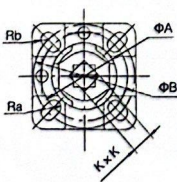
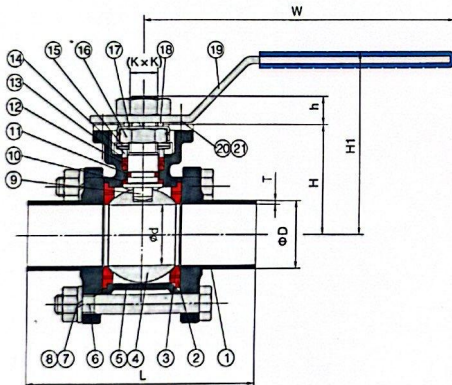
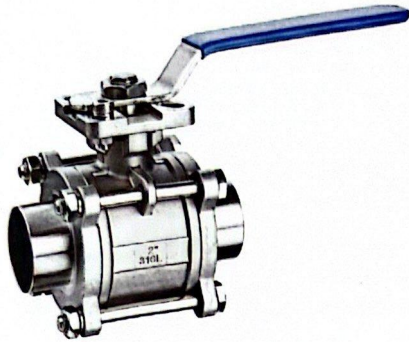

### 特点 Features

- 全通径 Full port, 1/2"~4" (DN15~DN100)
- 工作压力 W.P.: 1000WOG (PN63)
- 工作温度 W.T.: -20°C~180°C
- 精密铸造 Investment casting
- 阀杆防爆出装置设计 Blow-out proof stem
- 双碟形弹簧动负载设计 Live-loading design
- 防静电装置 (可选) Anti-static device (option)
- 全包式阀座 (可选) Cavity filled seats (option)
- 手柄带锁装置 (可选) Locking device handle (option)
- ISO5211直装高平台设计 ISO 5211 Direct mounting pad
- 自动化装置 (可选) Automation accessories (option)
- 对焊连接标准 Butt weld end: ASME BPE

### 材料表 Material List

序号No.	零件 PARTS	材料 MATERIAL		
1	阀盖 BONNET	CF8	CF8M	CF3M
2	垫片 GASKET	PTFE/TFM1600		
3	阀座 SEAT	PTFE/TFM1600		
4	球体 BALL	CF8	CF8M	CF3M
5	阀体 BODY	CF8	CF8M	CF3M
6	螺栓 BOLT	304		
7	弹簧垫圈 SPRING WASHER	304		
8	螺母 NUT	304		
9	阀杆 STEM	304	316	316L
10	阀杆垫圈 STEM WASHER	PTFE+25% GF		
11	O形圈 O-RING	FPM		
12	填料 PACKING	PTFE		
13	耐磨垫圈 WEAR WASHER	PTFE+25% GF		
14	填料盖 GLAND	304		
15	碟形弹簧 DISC SPRING	304		
16	螺母 NUT	304		
17	CROWN WASHER	304		
18	垫圈 WASHER	304		
19	手柄 HANDLE	304+PVC		
20	六角螺栓 HEX SOCKET BOLT	304		
21	螺母 NUT	304		

Unit: mm

### 尺寸 Dimensions

尺寸 SIZE	d	D	T	L	H	h	KxK	A	B	Ra	Rb	W	H1
1"	DN25	22	25	1.2	95	48	9 × 9	36	42	3.0	3.0	125	82
1-1/2"	DN40	35	38	1.2	120	61	9 × 9	42	50	3.0	3.5	140	95
2"	DN50	47.5	51	1.2	137	79	14 × 14	50	70	3.5	4.5	180	115
2-1/2"	DN65	59	63.5	1.6	143	88	14 × 14	70	102	4.5	5.5	180	124
3"	DN80	73	76.1	1.6	198	108	17 × 17	70	102	4.5	5.5	260	148
4"	DN100	97.5	101.6	2	246	130	17 × 17	70	102	4.5	5.5	260	170

# 3-PC BALL VALVE THREAD END 2000WOG DIRECT MOUNTING PAD

三片式2000 WOG 高平台球阀

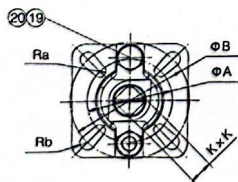
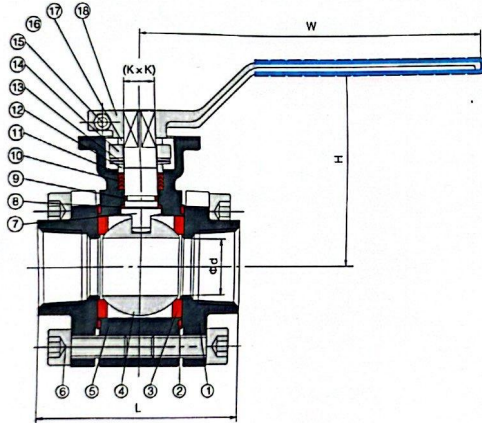
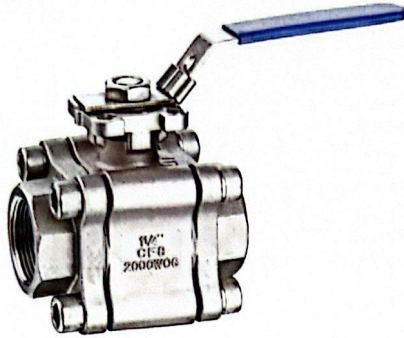

### 特点 Features

- 全通径 Full port, 1/4"~4" (DN6~DN100)
- 工作压力 W.P.: 2000WOG
- 工作温度 W.T.: -20°C~180°C
- 精密铸造 Investment casting
- 阀杆防爆出装置设计 Blow-out proof stem
- 双螺旋弹簧动负载设计 Live-loading design
- 防静电装置 (可选) Anti-static device (option)
- 手柄带锁装置 (可选) Locking device handle (option)
- ISO5211直装高平台设计 ISO 5211 Direct mounting pad
- 自动化装置 (可选) Automation accessories (option)
- 螺纹连接标准 Thread type: ASME B1.20.1 (NPT), DIN 259 / DIN 2999, BS 21, ISO 288-1, ISO 7-1
- 承插焊连接标准 Socket weld type: ASME B16.11 & DIN3239 part2
- 对焊连接标准 Butt weld type: ASME B16.25 & DIN3239 part1

### 材料表 Material List

序号No.	零件 PARTS	材料 MATERIAL		
		WCB	CF8	CF8M
1	阀盖 BONNET	WCB	CF8	CF8M
2	垫片 GASKET	PTFE		
3	阀座 SEAT	RPTFE/PEEK		
4	球体 BALL	CF8	CF8	CF8M
5	阀体 BODY	WCB	CF8	CF8M
6	六角螺栓 HEX SOCKET BOLT	304		
7	阀杆 STEM	304	304	316
8	阀杆垫圈 STEM WASHER	PTFE+25% GF		
9	O 形圈 O-RING	FPM		
10	填料 PACKING	PTFE		
11	耐磨垫圈 WEAR WASHER	PTFE+25% GF		
12	填料盖 GLAND	304		
13	碟形弹簧 DISC SPRING	304		
14	压盖法兰 GLAND FLANGE	CF8		
15	螺母 NUT	304		
16	六角螺栓 HEX SOCKET BOLT	304		
17	STOPPER	304		
18	手柄 HANDLE	WCB/CF8		
19	BOLT	304		
20	螺母 NUT	304		

### 尺寸 Dimensions

Unit: mm

尺寸 SIZE	d	L	W	KxK	A	B	Ra	Rb	
1/4"	DN6	10	68	140	9×9	36	42	3.0	3.0
3/8"	DN10	12	68	140	9×9	36	42	3.0	3.0
1/2"	DN15	15	76	140	9×9	36	42	3.0	3.0
3/4"	DN20	20	91	140	9×9	36	42	3.0	3.0
1"	DN25	25	102	170	11×11	42	50	3.0	3.5
1-1/4"	DN32	32	112	170	11×11	42	50	3.0	3.5
1-1/2"	DN40	38	125	200	14×14	50	70	3.5	4.5
2"	DN50	50	149	200	14×14	50	70	3.5	4.5
2-1/2"	DN65	65	185	300	17×17	70	102	4.5	5.5
3"	DN80	80	205	300	17×17	70	102	4.5	5.5
4"	DN100	100	240	300	17×17	70	102	4.5	5.5