

GATE VALVE THREAD END SOCKET WELD END

内螺纹闸阀

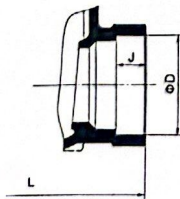
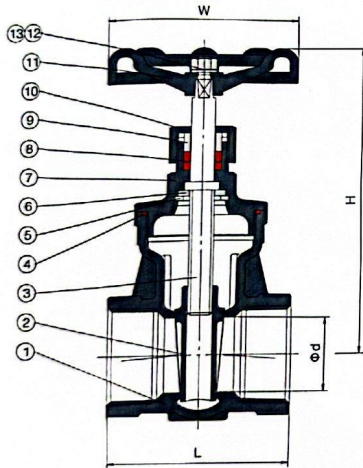

特点 Features

- 1/2'-2' (DN15~DN50)
- 工作压力 W.P.: 200WOG (PN16)
- 工作温度 W.T.: 425°C
- 精密铸造 Investment casting
- 非升杆式暗杆 Non-rising stem
- 螺纹连接标准 Thread end: ASME B1.20.1 (NPT),
DIN 259 / DIN 2999, BS 21,
ISO 288-1, ISO 7-1
- 承插焊连接标准 Socket weld end: ASME B16.11

材料表 Material List

序号No.	零件 PARTS	材料 MATERIAL		
		WCB	CF8	CF8M
1	阀体 BODY	WCB	CF8	CF8M
2	闸板 WEDGE DISC	CF8	CF8	CF8M
3	阀杆 STEM	304	304	316
4	垫片 GASKET	PTFE		
5	轴用挡圈 CIRCLIPS FOR SHAFT	304	304	316
6	垫圈 WASHER	304	304	316
7	阀盖 BONNET	WCB	CF8	CF8M
8	填料 PACKING	PTFE		
9	填料盖 GLAND	304		
10	阀盖螺母 BONNET NUT	WCB	CF8	CF8M
11	手轮 HANDWHEEL	ZL101		
12	平板 FLAT PAD	304		
13	螺母 NUT	304		

尺寸 Dimensions

Unit: mm

尺寸 SIZE		d	L	H	W	D	J
1/2'	DN15	15	52	97	70	21.8	9.5
3/4'	DN20	20	57.5	103	70	27.2	12.5
1'	DN25	25	61.5	113	70	33.9	12.5
1-1/4'	DN32	32	70.5	132	80	42.7	12.5
1-1/2'	DN40	40	74.5	156	100	48.8	12.5
2'	DN50	50	84	172	100	61.2	16